

Contents

1. Introduction	3
1.1. Purpose.....	3
1.2. Safety Notices	3
2. Product Identification	3
2.1. Product Identification	3
2.2. Initial inspection	4
2.3. Storage	4
3. General Information and Features	5
3.1. General	5
3.2. External Parts for Standard Models	7
3.3. Internal Parts for Standard Models	7
4. Installation Instruction.....	7
4.1. Pre-Installation for	7
4.2. Actuator Mounting	8
4.3. Limit Switch Setting.....	9
4.4. Force Switch Setting.....	10
4.5. Position Feedback Potentiometer (Optional)	10
4.6. Current Position Transmitter - CPT (Optional)	11
4.7. Proportional Control Unit (PCU-A)	13
4.8. Proportional Control Unit (PCU-D)	13
4.9. AC/DC Multi-Board	17
5. Wiring	18
5.1. Electrical Connections and Preliminary Test.....	18
5.2. Wiring Diagrams for Standard Models	18
6. Maintenance	20
6.1. Maintenance	20
6.2. Tools	21
7. Trouble Shooting.....	21
7.1. The actuator does not respond.....	21
7.2. The actuator is supplied with power but does not operate	21
7.3. Actuator runs erratically	21
7.4. Optional Equipment(s)	21
8. Installation and Maintenance Tips	22
9. Dimensions for actuator	23
9.1. 5KN,7KN, 10KN, 12KN, 15KN, 18KN, 20KN, 25KN (Standard type)	23
9.2. 5KN,7KN, 10KN, 12KN, 15KN, 18KN, 20KN, 25KN (LCU-B type)	23
9.3. 5KN,7KN, 10KN, 12KN, 15KN, 18KN, 20KN, 25KN (RBP type)	24
APPENDIX I . HL Series Coding System.....	25

1. Introduction

1.1. Purpose

The purpose of this manual is to introduce and explain the installation, operation and maintenance of HL-series electric actuators. This IOM Manual is distributed as a hard copy when delivered the ordered products to customer.

1.2. Safety Notices

Safety notices in this manual outline precaution the user must take to reduce the risk of personal injury and damage to the equipment. User(s) must read these instructions before the installation, operation or maintenance of HL-series electric actuators.



DANGER: Refers to personal safety and alerts the user to danger or harm. The hazard or unsafe practice will result in severe injury or death.



WARNING: Refers to personal safety. Alerts the user to potential danger. Failure to follow warning notices could result in personal injury or death.



CAUTION: Directs the user's attention to general precautions that, if not followed, could result in personal injury and/or equipment damage.

Notes: Highlighted information is critical to the user's understanding of the actuator's installation and operation.

2. Product Identification

2.1. Product Identification

The actuator name plate is located on the opposite side of the cable entry. The name plate contains the following:

2.1.1. Marking

① General

HL logo (trade mark), Electrical power supply, Model, Stroke, Rated current, Force(Thrust), Operating time, Serial No. and Option on a type of sticker

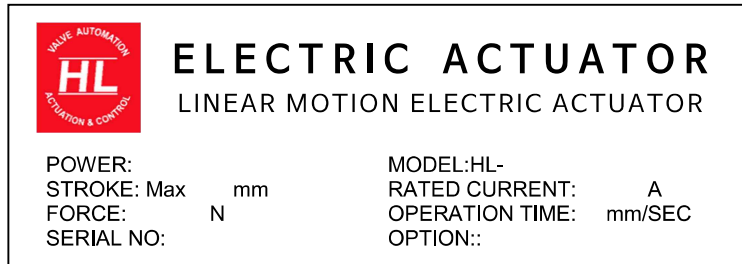

② Explosion Proof for IECEX/ATEX

Manufacturer, Actuator type, Address, Model, Electrical power supply, Serial No., Manufactured year & month, Cable entry, Certification number, Explosion proof type and application temperature range on a Stainless steel plate

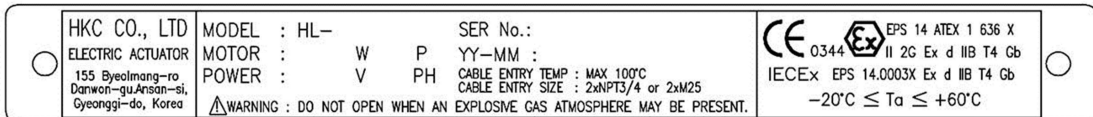

③ Explosion Proof for KCs

Manufacturer, Actuator type, Address, Model, Electrical power supply, Serial No., Manufactured year & month, Cable entry, Certification number, Explosion proof type and application temperature range on a Stainless steel plate

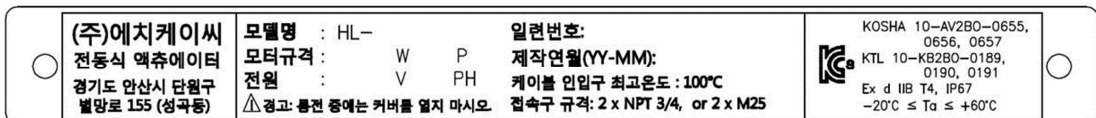

2.1.2. Applied Standard

- ① IEC60079-0:2011, EN60079-0:2012
- ② IEC60079-1:2007, EN60079-1:2007

2.1.3. Certification

- ① IECEX: for HL-05kN ~ HL-25kN, IECEX EPS 14.0003X
Ex d IIB T4 Gb, Ta -20°C to +60°C
- ② ATEX: for HL-05kN ~ HL-25kN, EPS 14 ATEX 1 636 X, CE 0344
II 2G Ex d IIB T4 Gb, Ta -20°C to +60°C
- ③ KCs(KOSHA) for standard type HL-05/07kN, 10-AV2BO-0655,
for standard type HL-10/12/15kN, 10-AV2BO-0657,
for standard type HL-18/20/25kN, 10-AV2BO-0659, Ex d IIB T4, -20°C ~ +60°C
for HL-05/07kN with SICU(LCU), 10-AV2BO-0656,
for HL-10/12/15kN with SICU(LCU), 10-AV2BO-0658,
for HL-18/20/25kN with SICU(LCU), 10-AV2BO-0660, Ex d IIB T4, -20°C ~ +60°C
KCs(KTL) for standard type HL-05/07kN, 10-KB2BO-0190,
for standard type HL-10/12/15kN, 10-KB2BO-0191,
for standard type HL-18/20/25kN, 10-KB2BO-0189, Ex d IIB T4, -20°C ~ +60°C



Notes :

- Sealing devices must be used and shall be fitted directly at enclosure wall when using conduit.
- Cable glands shall be suitable for the environment and shall be certified as flameproof if used in Zone 1 application.
- Cable glands and conduit to be installed minimum 6 full threads and the length of thread is minimum 8mm.
- Temperature of cable entry is maximum 100°C. Heat resistance wire is recommended when you install.
- Ex d certified cable glands suitable for 100°C must be used.
- Users should confirm all information about dimensions of flamepath with the manufacturer
- All information about the material and the allowance of LCU fasteners
 - Fasteners with yield stress \geq 210MPa (stainless steel)
 - Bolts type : M5*0.8, M6*1, M8*1.25, M10*1.5, M12*1.75 (Tolerance Fit 6g)
- Cable connection : Refers to the Appendix II (Wiring Diagram)
- For cable entries or conduit entries that are not used, user or installer shall close by certified blanking elements(stopping plugs) so that the flameproof properties of the enclosure are maintained.
- Always ground the enclosure in accordance with local electric codes. The most effective enclosure grounding method is a direct connection to earth ground with minimal impedance. Methods for grounding the enclosure include:
 - Internal ground connection : The internal ground is located in the terminal block #1. Refer to the enclosed wiring diagram.
 - External ground connection : The ground lug is located on the centre of cable entries.
 - For more information, refer to the Appendix III (Grounding)

2.2. Initial inspection

When the user receives the actuators, inspect the condition of the product and ensure the name plate comparing with order sheet.

- 2.2.1. Remove packing wrap or wooden box carefully. Inspect the product for any physical damage that may have occurred during shipment.
- 2.2.2. Check the product specification with product ordered. If an wrong product have been shipped, immediately inform to our coordinator.

2.3. Storage

Actuators must be stored in a clean, cool and dray area. The unit should be stored with the cover installed and the cable entry openings sealed. Storage must be off the floor, covered with a sealed dust protector. When actuators are to be stored outdoor, they must be stored off the ground, high enough to prevent from being immersed in water or buried in snow.

3. General Information and Features

3.1. General

HKC HL series electric actuators are designed for the operation of industrial valves, e.g. globe valves and gate valves.

Actuator force ranges from 5000n to 25,000Nm, currently eleven models are available:

HL-5KN, 7KN, 10KN, 12KN, 15 KN, 18KN, 20KN, 25KN

3.1.1. Performance

Type HL-	Max. output force	Operating time (mm/sec.)	Max. Stroke	Duty IEC 60034-1	Rated current (A) 50/60Hz						No. of handle turn	Wgt. kg
					dc	ac 1 Phase		ac 3 Phase				
						24 V	110 V	220 V	380 V	440 V		
05kN	5	0.44/0.53	60	50	2.1	1.0/1.0	0.6/0.5	0.3/0.3	0.6/0.4	NA	227	11
07kN	7	0.44/0.53	60	50	2.7	1.2/1.1	0.6/0.6	0.3/0.4	0.6/0.5	NA	227	11
10kN	10	0.69/0.82	70	50	3.9	1.9/1.8	0.9/0.9	0.6/0.4	0.6/0.4	0.6/0.3	184	21
12kN	12	0.69/0.82	70	50	4.6	2.1/2.0	1.0/1.0	0.7/0.5	0.6/0.4	0.6/0.4	184	21
15kN	15	0.69/0.82	80	50	5.6	2.2/2.1	1.1/1.1	0.7/0.5	0.7/0.4	0.6/0.4	210	21
18kN	18	0.69/0.83	100	50	5.8	1.8/2.0	0.9/1.1	0.6/0.5	0.4/0.3	0.4/0.3	260	33
20kN	20	0.69/0.83	100	50	6.4	2.1/2.4	1.0/1.2	0.7/0.6	0.7/0.5	0.7/0.5	260	33
25kN	25	0.69/0.83	100	50	7.8	3.2/4.0	1.9/2.1	0.9/0.8	0.8/0.6	0.8/0.6	260	33

3.1.2. Standard Technical Data

Enclosure Rated	Weatherproof IP67
Enclosure	High grade aluminium alloy, corrosion coated
Power Supply	24Vdc, 110/220Vac 1Ph, 380/440/460Vac 3Ph, 50/60Hz, ±10%
Duty type (on-off)	S4 40~70% @ 50% load modulating, S2 30min @50% load on-off
Motor	Reversible induction motor
Limit Switches	2 x open/close SPDT, 250 V ac 16A rating
Auxiliary Limit Switches	2 x open/close SPDT, 250 V ac 16A rating (except HL05~07KN)
Force Switches	Open/close SPDT, 250V ac 16A
Stall Protection	Built - in thermal protection, open@150±5, close @97±15℃
Manual Override	Decutching mechanism
Self-Locking	Provided by double worm gear
Space Heater	for anti-condensation, please see clause 3.1.5.
Cable Entries	Standard: 2 x PF3/4", flameproof: 2 x NPT3/4" or 2 x M25
Lubrication	Standard: grease moly (EP), for low temp.: Tribolube-18
Ambient Temperature	Standard: -20℃ ~ +70℃, Flameproof: -20℃ ~ +70℃,
External Coating	Anodizing and thermally hardened polyester powder coating

3.1.3. Optional Technical Data

EXD	Flame proof enclosure (Ex d IIB T4)
WTA	Watertight enclosure (IP68 10m 72hr)
PIU	Potentiometer unit (0~1kΩ)
CPT	Current position transmitter (output 4~20mA dc)
PCU	Proportional control unit (input, output 0~10 V dc, 4~20mA dc)
IMS	Integral magnetic starter (control 110/220 V ac 1ph, 50/60Hz, ±10%)
LCU-B	Local / remote control unit
LCU-C	Integral control unit (LCU+IMS+auto phase discriminator)
RBP	Rechargeable battery backup for ESD (Emergency Shut Down)
MSB	Mounting support base & driving rod

3.1.4. Duty Cycle ¹⁾

Duty cycle rated IEC60034-1, S4 50% / S2 30min

Exceeding the actuator's rated duty cycle may cause thermal overload.

Note 1) Type of duty expression according to VDE 0530 / IEC 60034-1

Short – time duty S2	Intermittent duty S4
The operation time at a constant load is short, so that thermal equilibrium is not reached. The pause is long enough for the machine to cool down to ambient temperature. Example, the duration of the short -time operation is limited to 15min	The duty is a sequence of identical cycles which consist of starting time, operation time with constant load and rest period. The rest period allows the machine to cool down so that thermal equilibrium is not reached. Example, the relative on-time at S4-25% or S4-50% is limited to 25% and 50% respectively.

3.1.5. Heater

Condensation in the actuator is possible due to wide fluctuation of the ambient temperature. The heater integrated in the control unit prevents this in general.

Model	24V dc	110V ac 1ph	220V ac 1ph	220~460V ac 3ph
HL-05/07kN	5W 200Ω	5W 4.5kΩ	5W 18kΩ	5W 18kΩ
HL-10/12/15kN	10W 100 Ω	10W 2kΩ	10W 8kΩ	10W 8kΩ
HL-18/20/25kN	10W 100 Ω	10W 2kΩ	10W 8kΩ	10W 8kΩ

3.1.6. Hand wheel and Declutching

HL actuators are provided a declutchable manual override system.

- ① In order to manually operate the actuator, pull the manual override engagement lever towards the hand wheel until it remains in position.
- ② Turn the hand wheel until the valve reaches the required position
- ③ Turn clockwise to close(down) and counter-clockwise to open (up)

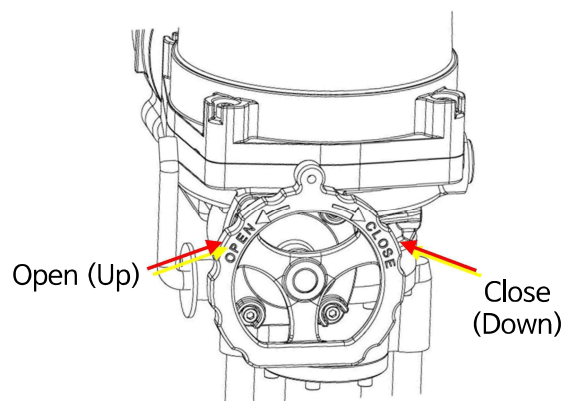
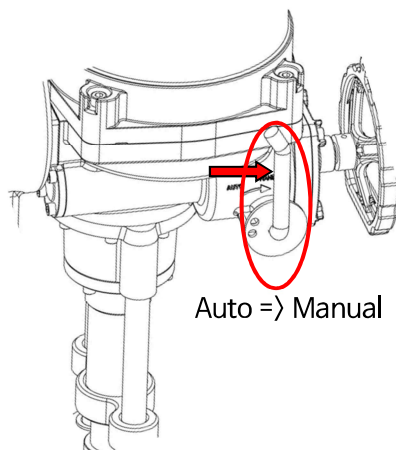

Note ; The override engagement lever returns automatically to auto position when the actuator is electrically operated.

3.1.7. Lubrication

HL is a totally enclosed unit with a permanently lubricated gear train (Moly EP Grease). Once installed lubrication should not be required. However, periodic preventative maintenance will extend the operating life of the actuator.

3.2. External Parts for Standard Models

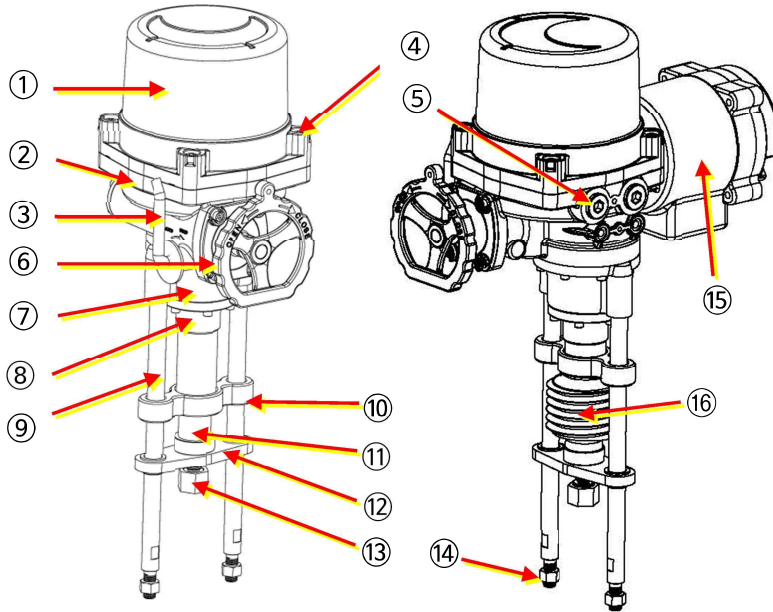

External Parts	
1	Top Cover
2	Body
3	Declutch lever
4	Cover bolt
5	Cable Entries (NPT 3/4")x2
6	Manual hand wheel
7	Upper Base
8	Bridge Base
9	Guide rod
10	Guide rod Holder
11	Driving rod
12	Locking plate
13	Union joint & nut
14	Guide rod nut
15	LCU Unit (Optional)
16	Driving rod rubber (Optional)

3.3. Internal Parts for Standard Models

Internal Parts	
1	Motor
2	Potentiometer
3	Terminal
④	Open force switch (RED Color)
⑤	Close force switch (BLUE Color)
6	Close limit switch
⑦	Open limit switch
8	Capacitor
9	PCU Board
10	Heater

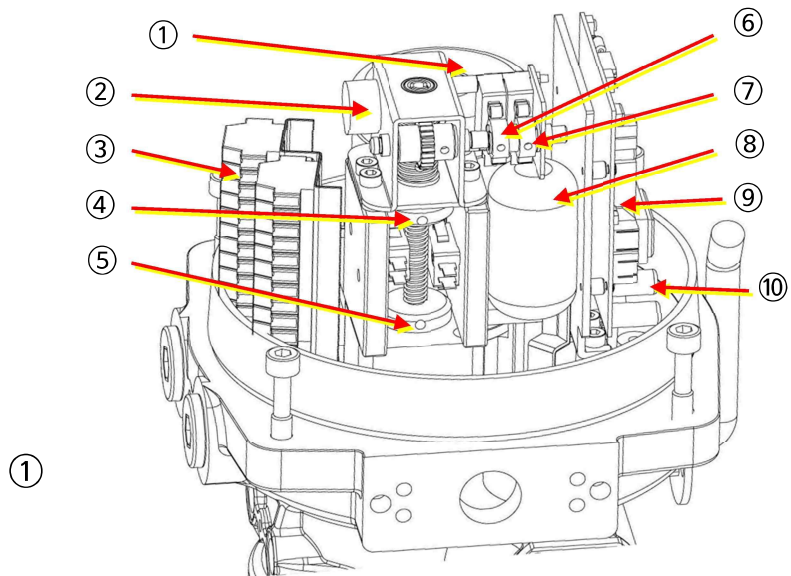

4. Installation Instruction

4.1. Pre-Installation for

4.1.1. use in general service

Verify the actuators nameplate to ensure correct model number, force, operating speed, voltage and enclosure type before installation or use.

It is important to verify that the output force of the actuator is appropriate for the force requirements of the valve and that the actuator duty cycle is appropriate of the intended application.

4.1.2. use in potentially explosive atmosphere

Model HL - ... 1.0 ... 0¹⁾
Type of enclosure II 2G Ex d IIB T4

Ambient temperature -20 deg C ~ + 70 dec C
 Installation, commissioning, maintenance, repairs and modification work must only be performed by qualified personnel with extensive knowledge on how to work on flame-proof electrical equipment.



Note : ¹⁾ Further information should be use of the HL electric actuator catalogue.
 Refers to the Cl.2.2 this manual.



Warning : *Read this installation and maintenance manual carefully and completely before attempting to install, operate, or troubleshoot the HKC actuator.*

4.2. Actuator Mounting



Note :

- Prior to mounting the linear actuator must be checked for any damage.
- Damaged parts must be replaced by original spare parts.

Mounting is most easily done with the valve shaft pointing vertically upward. But mounting is also possible in any other position.

The HL- Series actuators are supplied with a Union joint & nut.

The actuator Union joint is removable for ease of machining.



Caution :

*Do not attempt to work on your HKC actuator without first shutting off incoming power.
 Do not attach ropes or hooks to the hand wheel for the purpose of lifting by hoist.*

4.2.1. Actuator Mounting Details

If the linear actuator and the valve are supplied separately you will have to mount the linear actuator on the valve.

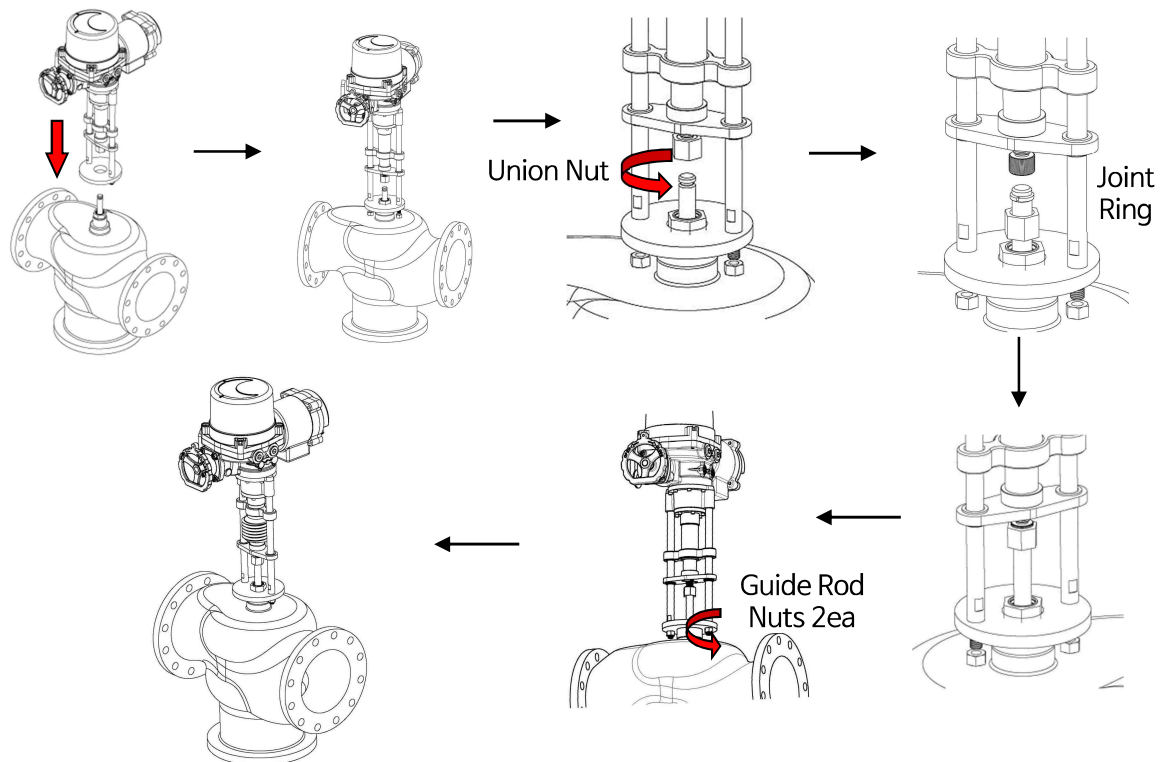

4.2.2. Preparing assembly



Warning : A non-attached valve causes damage!



If you operate the linear actuator without valve, the spindle nut may fall off due to the missing stop.

CAUTION: Always operate the linear actuator with a valve attached.

Allow for about 200 mm space above the cover at the site of installation. Check the working environment before assembling and commissioning the linear actuator. Ensure that the valve is correctly fitted. For details please see assembly instructions for valve. Determine the assembly position of the linear actuator. Do not arrange linear actuators in a hanging position.

4.3. Limit Switch Setting

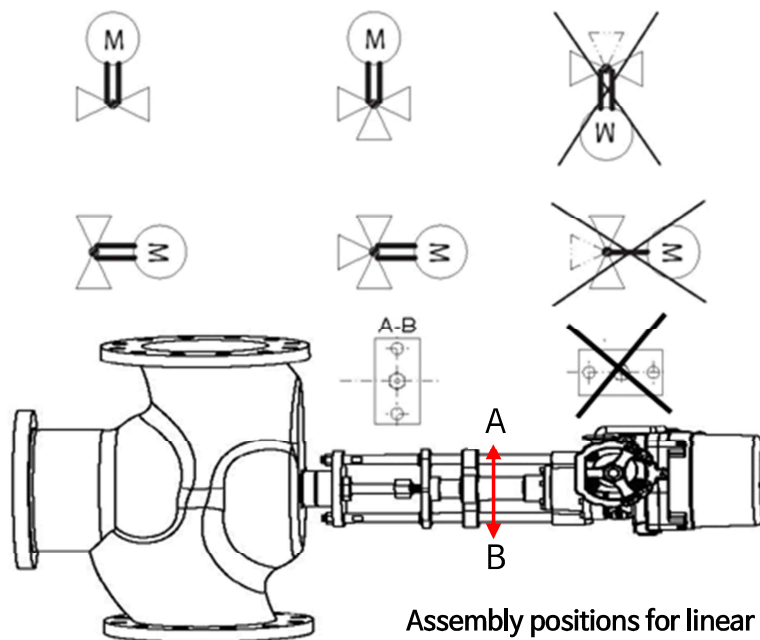

Assembly positions for linear actuator and valve

- 4.3.1. Rotate the actuator hand wheel manually to closed position
- 4.3.2. Using a hex wrench, loosen the set screw in the CLOSE limit switch cam
- 4.3.3. Rotate the CLOSE cam towards CW limit switch lever until the switch 'clicks' (Fig 1)
- 4.3.4. Tighten the set screw with hex wrench
- 4.3.5. Rotate the actuator hand wheel manually to open position
- 4.3.6. Using a hex wrench, loosen the set screw in the OPEN limit switch cam
- 4.3.7. Rotate the OPEN can towards CCW limit switch lever until the switch 'clicks' (Fig 2)
- 4.3.8. Tighten set screw with hex wrench



Danger : HAZARDOUS VOLTAGE. Make sure all power is disconnected before making the setting.

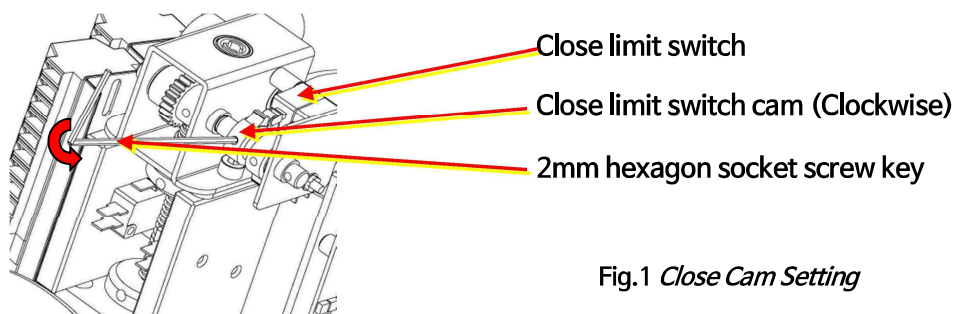
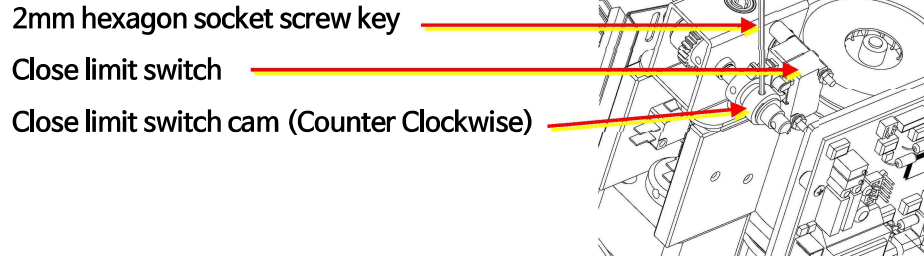

Fig.1 Close Cam Setting

Fig.2 Open Cam Setting



4.4. Force Switch Setting

Force spring which detects the variation of force during operation is installed for preventing damage of valve and actuator under overload condition. Once actuator is under overload, force switch is tripped and actuator stopped immediately.

The force switches are set by manufacturer on the production site basically.

Re-setting is necessary; please contact the HKC service or representative before setting.



Caution : Do not reset force switch to a setting higher than the maximum recommended by the manufacturer.

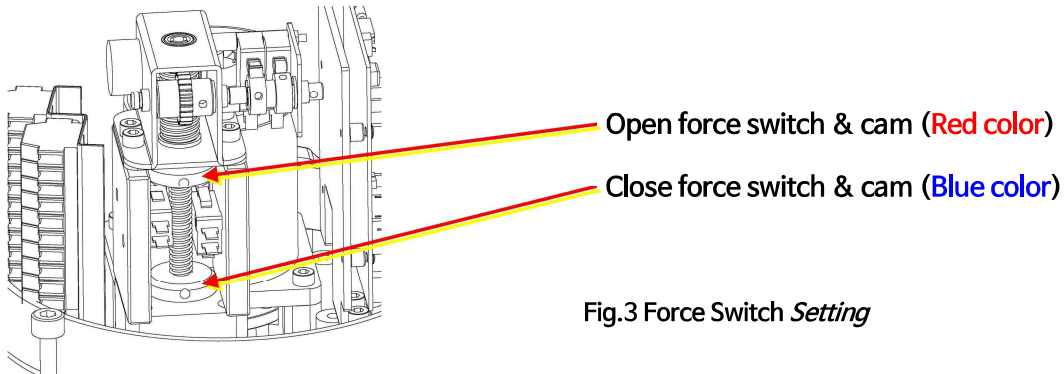

Fig.3 Force Switch Setting

4.5. Position Feedback Potentiometer (Optional)

4.5.1. Calibration Potentiometer

The potentiometer has been calibrated at the factory. However, if re-calibration is required, proceed as follows:

- ① Apply power (or use manual override) to drive the actuator to its true closed position (clockwise rotation).
- ② Connect an ohmmeter to P1 (red) and P3 (black) resistance should be approximately 1000ohms
- ③ Put actuator full close(down) position.
- ④ Loosen the point shaft gear and connect the ohmmeter to P1 (red) and P2 (white) and gently rotate until a reading of 80-120 Ω is achieved (100 ohms preferred).
 {Full close range: 0~100Ω Full open range:700~900Ω}
 While maintaining this reading tighten the point gear set screw with an hex wrench(HL5,7KN).
- ⑤ Engage potentiometer spring between gear and pointer shaft (refer diagram B)

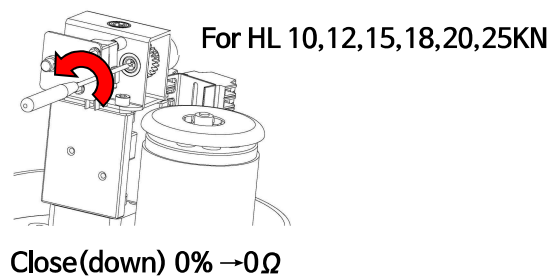
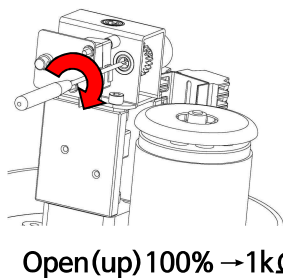

For HL 10,12,15,18,20,25KN

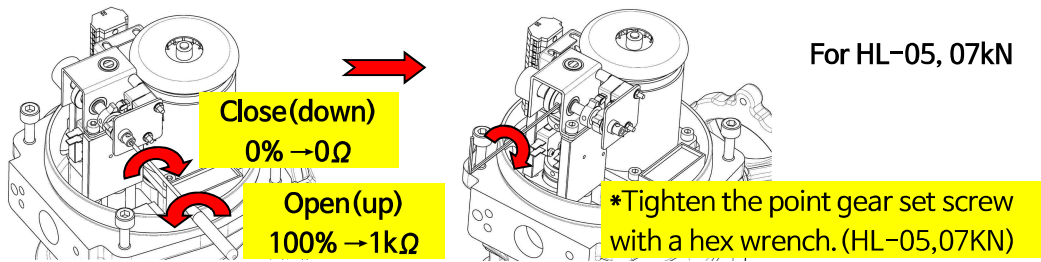

Fix potentiometer by placing spring as per diagram A (HL 10,12,15,18,20,25kN)

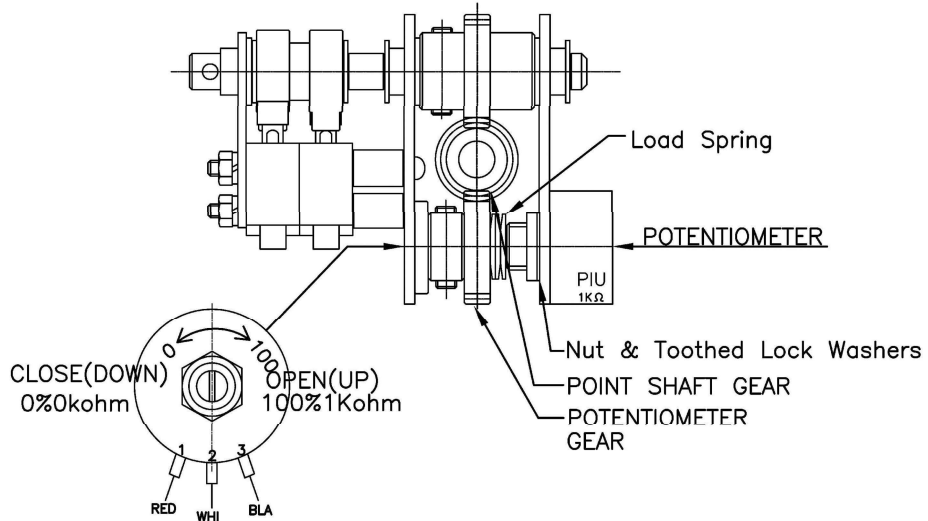
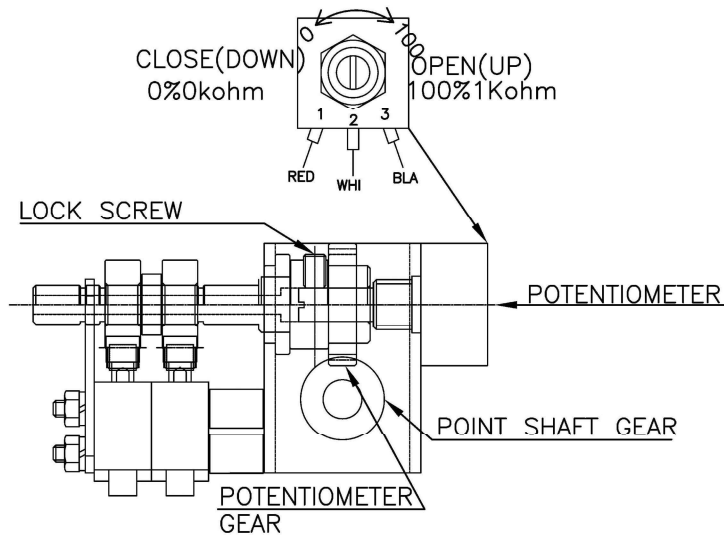

Diagram B (HL 5,7kN)



4.6. Current Position Transmitter - CPT (Optional)

The potentiometer is used for the actuator signal feedback. It reads a resistance value corresponds to the current position of the actuator and transfers to CPT card. The CPT indicates the current position of the actuator throughout the stroke by a 4 ~ 20mA output signal.

4.6.1. Standard Features

Model	CPT
Power	220(110)Vac, 50/60Hz, 2VA max
Output Signal	4~20mA DC
Output Impedance	750Ω max
Resolution	Min 1/1000
Position Conversion Accuracy	±0.5 ~ ±1.5%
Ambient Temperature	-20 °C to +70 °C
Ambient Humidity	90% RH max (Non-condensing)
Dielectric Strength	1 sec at (Rated Vac x 2 + 1000) x1.2 (from Input to power ground)
Insulation Resistance	Above 500Vdc 30MΩ
Vibration	10g, 0~34Hz



DANGER:

HAZARDOUS VOLTAGE. Make sure all incoming power is disconnected before setting the potentiometer

4.6.2. Calibration of Zero and Span - CPT

The settings of Zero and Span have been calibrated at the factory. However, if re-calibration is required, proceed as follows:

- ① Use the manual override to drive the actuator to a half open position.
- ② Apply power (or use the manual override) to drive the actuator to its fully closed position (clockwise rotation).
- ③ When the actuator is in the fully closed position, adjust the ZERO dial on the CPT board until a reading of 4mA is achieved.
- ④ Apply power (or use the manual override) to drive the actuator to its fully open position (counter-clockwise rotation).
- ⑤ When the actuator is in the fully open position, adjust the SPAN dial on the CPT board until a reading of 20mA is achieved.

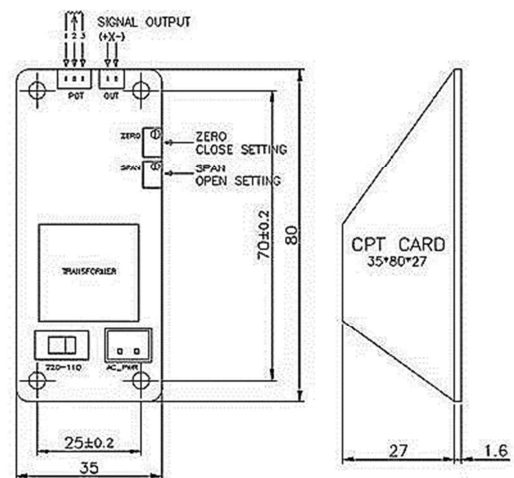

4.7. Proportional Control Unit (PCU-A)

PCU-Rev-4 High Performance Controller, using 10 bit A/D converter and 8bit microprocessor technology

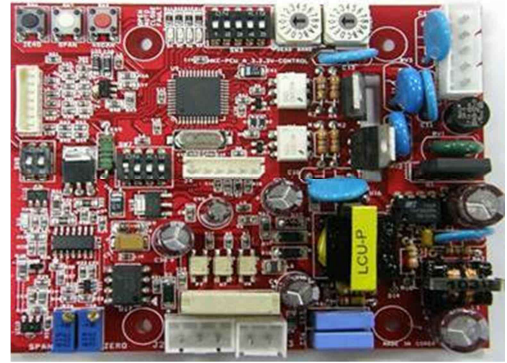

PCU-Rev-4 Features	
Model	PCU-Rev-4
Power	85 ~ 260 VAC Free Voltage \pm 10%, 50/60Hz 4 VA Max
Input Signal	4~20mA DC, 1~5V DC, 2~10V DC, 0~5V DC, 0~10V DC
Input Impedance	250 Ω
Output Signal	4~20mA DC, 1~5V DC, 2~10V DC, 0~5V DC, 0~10V DC
Output Impedance	750 Ω Max
Output Contact	1 (Fault monitor)
Delay Time Adjustment	0.05~7.5 seconds
Deadband Adjustment	0.12mA DC Max
Resolution Adjustment	0.0625~1mA (0.0625mA + step no. x 0.0625mA, 15 steps total)
Ambient Temperature	-10 $^{\circ}$ C to +70 $^{\circ}$ C
Ambient Humidity	90% RH Max (non-condensation)



NOTE :The factory settings of the PCU card are normally set according to the customer requirements at the time of order. However, we strongly recommend that input power, signal input selection and dip switches are to be verified prior to the actuator start up.

4.8. Proportional Control Unit (PCU-D)

PCU-Rev-D1 High Performance Controller, using 10 bit A/D converter and 8bit microprocessor technology

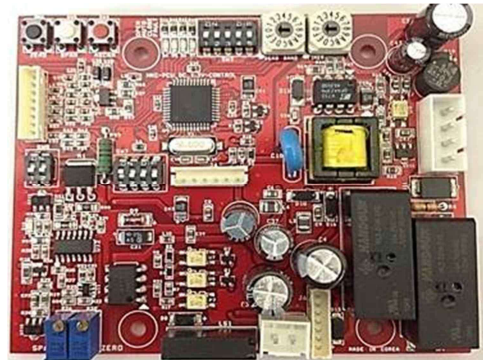

PCU-Rev-D1 Features	
Model	PCU-Rev-D1
Power	24V DC Voltage \pm 15% (36V DC Max)
Input Signal	4~20mA DC, 1~5V DC, 2~10V DC, 0~5V DC, 0~10V DC
Input Impedance	250 Ω
Output Signal	4~20mA DC, 1~5V DC, 2~10V DC, 0~5V DC, 0~10V DC
Output Impedance	750 Ω Max
Output Contact	1 (Fault monitor)
Delay Time Adjustment	0.05 ~ 7.5 seconds
Deadband Adjustment	0.12mA DC Max
Resolution Adjustment	0.0625~1mA (0.0625mA + step no. x 0.0625mA, 15 steps total)
Ambient Temperature	-25 $^{\circ}$ C to +80 $^{\circ}$ C
Ambient Humidity	90% RH Max (non-condensation)

4.8.1. LED Signal Indication

LED	State	Indication
Blue	On	Power on (auto)
	Flickering	Auto calibrating
Green	On	Fully closed
	Flickering	Closing
Red	On	Fully open
	Flickering	Opening
Yellow	On	Manual mode
	Flickering	Fault indication, either: - no input signal - wrong input wiring - wrong PIU setting

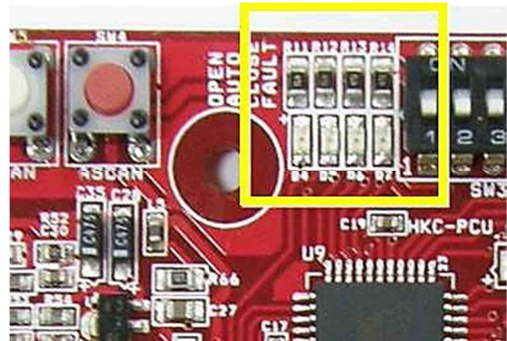

4.8.2. Setting PCU Functions

① Selecting Input Signal

User can select different types of input signal by adjusting the DIP switches as follows:

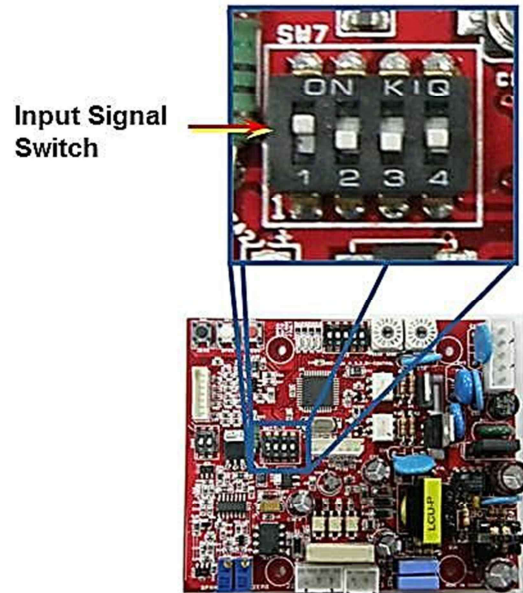
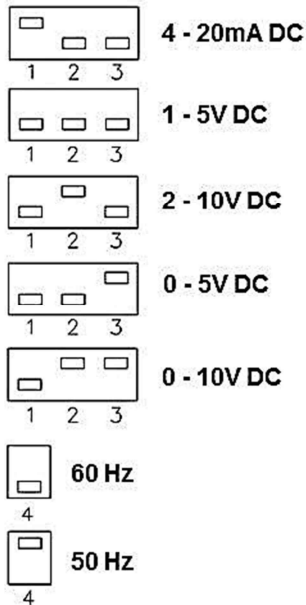

NOTE:

If not specified, the factory setting of the input signal is 4 - 20mA.

② Selecting Output Signal

User can select different types of output signal by adjusting the DIP switch as follows:

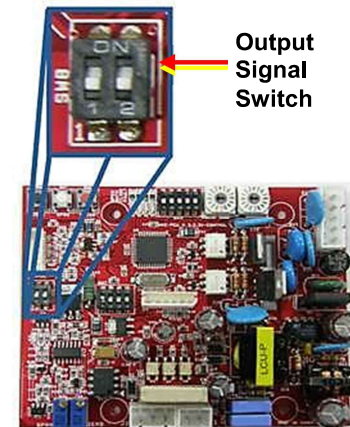
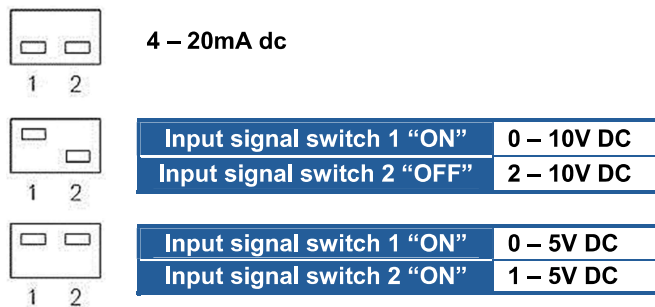

NOTE: If not specified, the factory setting of the input signal is 4 - 20mA.

③ Fail Position Setting

User can select the fail position of the actuator in case of control signal failure by adjusting the DIP switches as follows:

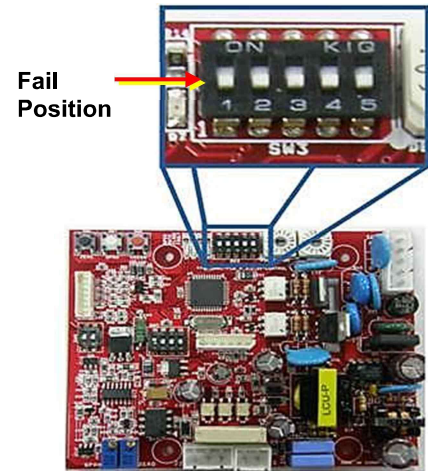
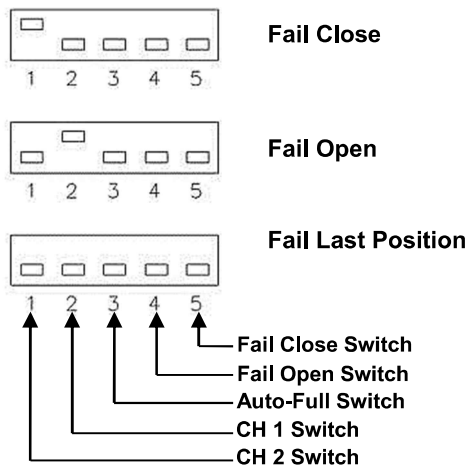

④ Special Signal Setting for Fully Open and Fully Closed

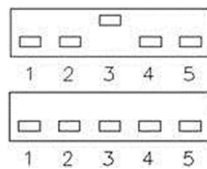

Auto-Full Switch (Switch 3) On (up)	Signal: 4.3mA	Fully Closed
	Signal: 19.7mA	Fully Open
Auto-Full Switch (Switch 3) Off (down)	Signal: 4mA	Fully Closed
	Signal: 20mA	Fully Open

⑤ Auto Setting

- This function is used for automatic setting of the PCU card to the predefined limits.
- While the actuator is corrected mounted on the valve, check input power, input and output signal connections. Press ASCAN button once, regardless of the position of the actuator, then the actuator will perform the Auto Setting motion:
 - ◆ The blue LED flicker
 - ◆ Opening (the red LED flickering) for 5 seconds
 - ◆ Pause for 2 seconds
 - ◆ Fully closing (the green LED flickering)
 - ◆ Pause (the green LED on) for 3 seconds
 - ◆ Fully opening (the red LED flickering)
 - ◆ Pause (the red LED on) for 3 seconds
 - ◆ Moving back to the previous position

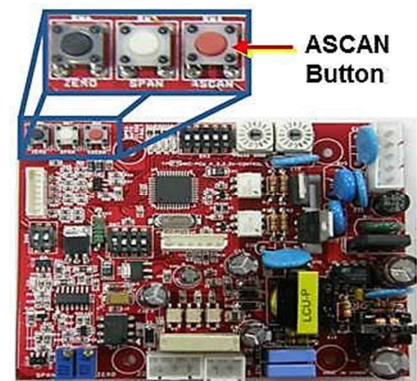

NOTE:

Since the unit is already set at the factory, no further setting is required unless the user has adjusted the mounting state of Limit Switch or the Potentiometer.

⑥ Manual Operation

- This function allows the user to manually operate the actuator.
- To access this function, press the ZERO (black) and SPAN (white) buttons simultaneously for 2 seconds and the yellow LED will be lit to indicate that the actuator is in Manual Operation mode

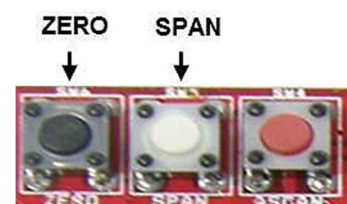

- Pressing the ZERO button will move the actuator to close and pressing the SPAN button will move the actuator to open
- If no operation occurs within 5 seconds, the PCU automatically terminates the Manual Operation mode or alternatively press the ZERO and SPAN buttons simultaneously for 2 seconds. In either case, the yellow LED will be lit off to indicate the termination of the Manual Operation Mode.



Note:

During the Manual Operation mode, the input signal is ignored.

⑦ **Customizing Set-points (CH 1 Switch)**

- This function is used when the user wants to set different set-points for fully open and fully closed positions.
- For example, if the user wants to assign 5mA as the set-point for fully closed position, first of all switch-on (move up) the CH1 switch (switch 4). Supply a 5mA signal and push the ZERO button once. Hereafter, the actuator will acknowledge 5mA signal as the set-point for fully closed position and transmits 4mA feedback signal. Similarly, for setting the set-point for the fully open position, supply the desired signal (for example, 19mA) and push the SPAN button once. Switch-off (move down) the CH1 switch to complete the setting.

Set-points	Adjustable Range
Fully Closed	3 – 8mA DC
Fully Open	16 – 21mA DC



⑧ **Reversal Acting (CH 2 Switch)**

- This function allows the user to reverse the input and output signals for the operation of the actuator.
- For standard operation (CH 2 switch down), the input signal of 4mA operates the actuator to fully close and the actuator transmits the output signal of 4mA. However, when CH 2 switch is on (move up) the input signal of 4mA operates the actuator to fully open and still transmits 4mA output signal.

CH 2 Switch (Switch 5) On (up)	4mA DC	Fully Open
	20mA DC	Fully Closed
CH 2 Switch (Switch 5) Off (down)	4mA DC	Fully Closed
	20mA DC	Fully Open

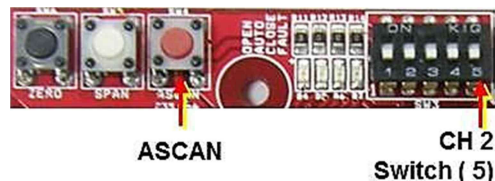

- Manually move the actuator to half-open position and push ASCAN button once to execute the Auto Setting (see 4.10.2 ⑤). Supply signal and check the operation.

⑨ **Delay Time**

- The actuator starts to move if and only if the change in the input signal value is greater than the resolution set value (see 4.8.2 J) and when the signal value is maintained for the duration of the delay time.
- This prevents malfunction of the actuator caused by unwanted signals in the input signal such as noise and interferences
- Turning the Delay Time Dial in clockwise direction will increase the delay time (Range 0.05 to 7.5 seconds).

Dial	0	1	2	3	4	5	6	7
sec	0.05	0.2	0.4	0.6	0.8	2.5	3.0	3.5
Dial	8	9	A	B	C	D	E	F
sec	4.0	4.5	5.0	5.5	6.0	6.5	7.0	7.5

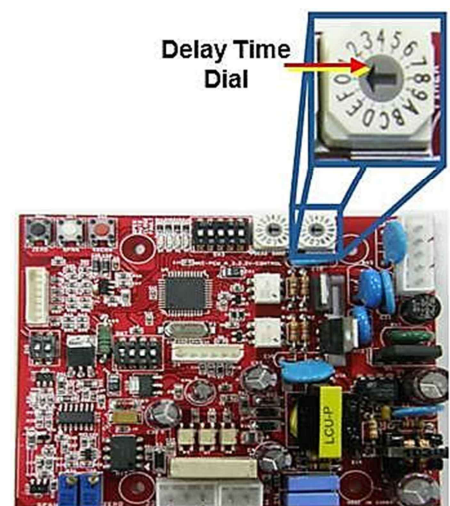

⑩ **Resolution**

- The deadband adjusts the limits of the valve's deviation between an actual position and a target position. The deadband is set to 0.12mA DC Max.
- Resolution indicates the extent of the reaction on the input signal.
- Low resolution setting may cause the actuator to hunt or to unnecessarily respond to a fluctuating input signal. If so, the resolution must be increased.
- Turning the Resolution Dial in clockwise direction will increase the resolution (Range 0.0625mA to 1mA).



Dial	0	1	2	3
mA DC	0.0625	0.125	0.1875	0.25
Dial	4	5	6	7
mA DC	0.3125	0.375	0.4375	0.5
Dial	8	9	A	B
mA DC	0.5625	0.625	0.6875	0.75
Dial	C	D	E	F
mA DC	0.8125	0.875	0.9375	1

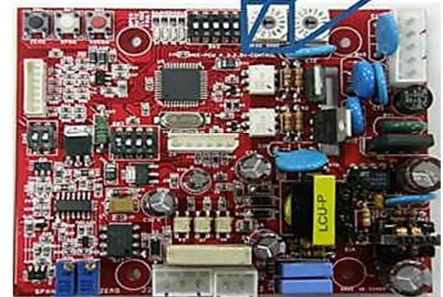

4.9. AC/DC Multi-Board

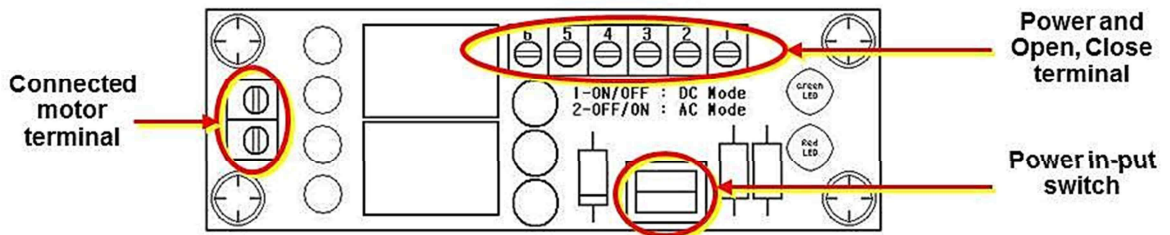

4.9.1. Power Open and Close terminal

- ① Power 24V AC/DC (DC + signal block)
- ② None
- ③ None
- ④ Open signal
- ⑤ Close signal
- ⑥ Power 24V AC/DC (DC - signal block)

4.9.2. Chooses switch for power signal

- ① As using for AC Mode, #1 switch turn on and #2 switch turn off
- ② As using for DC Mode, #1 switch turn off and #2 switch turn on

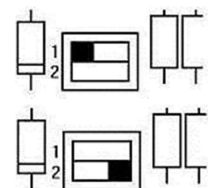

NOTE: Don't turn on both switch #1 and #2 at the same time that become a reason of damage of the board

③ **Motor connect Block**

- Red motor wire to connect #1 block
- Black motor wire to connect #2 block

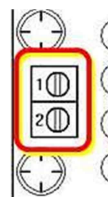

5. Wiring

5.1. Electrical Connections and Preliminary Test



WARNING:

- ✓ *When working in potentially explosive atmospheres, observe the European Standards EN 60079-14 “Electrical Installation in Hazardous Areas” and EN 60079-17 “Inspection and Maintenance of Electrical Installations in Hazardous Areas”.
Work on the electrical system or equipment must only be carried out by a skilled electrician himself or by specially instructed personnel under the control and supervision of such an electrician and in accordance with the applicable electrical engineering rules.*
 - ✓ *For cable gland or cable entries that are not used, user or installer shall close by certified blanking elements so that the flameproof properties of the enclosure are maintained*
 - ✓ *Flameproof enclosure! Treat cover with care. Gap surfaces must not be damaged in any way. Do not jam cover during fitting.*
- 5.1.1. For testing purposes, loosen the bolts on the actuator cover and remove the cover.
 - 5.1.2. Make sure that the power supply voltage is in accordance with the data on the nameplate of the actuator.
 - 5.1.3. Pass cables through the cable glands: NPT 3/4” or M25 for Ex “d”
 - 5.1.4. Connect wires according to the enclosed wiring diagram.
 - 5.1.5. Manually move the valve to half-open position. Then electrically operate the actuator to fully open position and check if the motor rotates in correct direction; standards units are counter-clockwise to open.
 - 5.1.6. Test the actuator and check whether the limit switches work correctly
 - 5.1.7. After the testing, check that all cable glands are correctly tightened. Applicable cable glands should be selected to meet the application’s condition. It is recommended to use the grade of IP67 cable gland or higher in potentially explosive atmosphere.
 - 5.1.8. Put carefully the cover on the body and tighten the bolts.

5.2. Wiring Diagrams for Standard Models

5.2.1. On/off type

(HL 5KN,7KN,10KN,12KN,15KN)

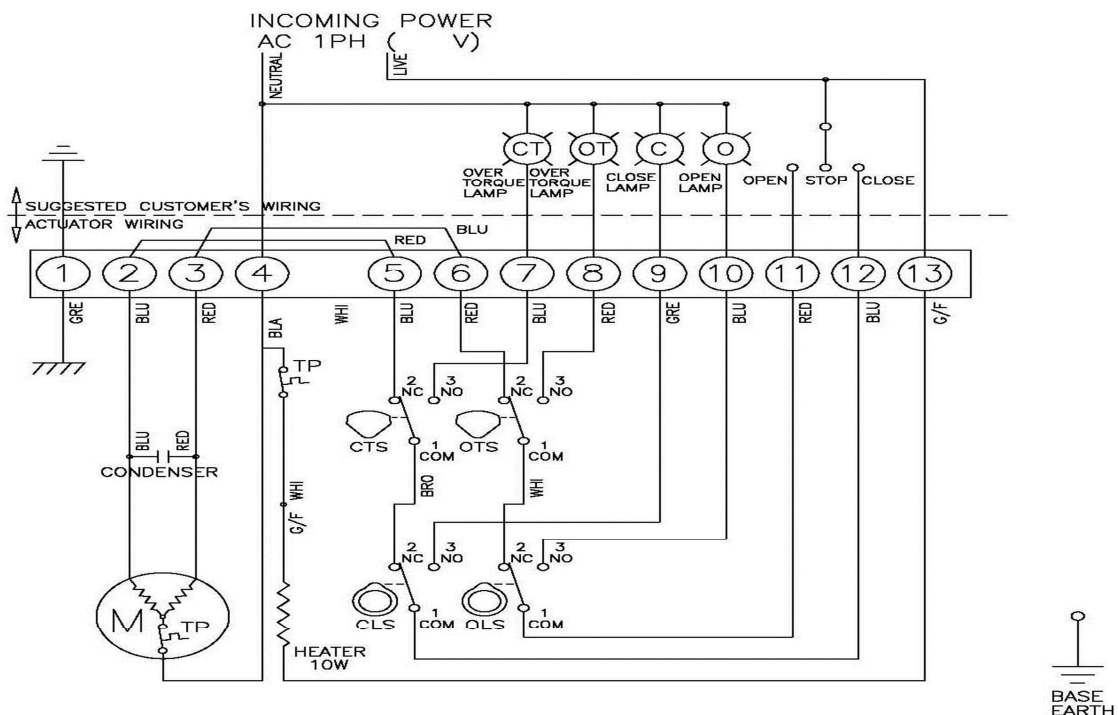

(HL 18KN,20KN,25KN)

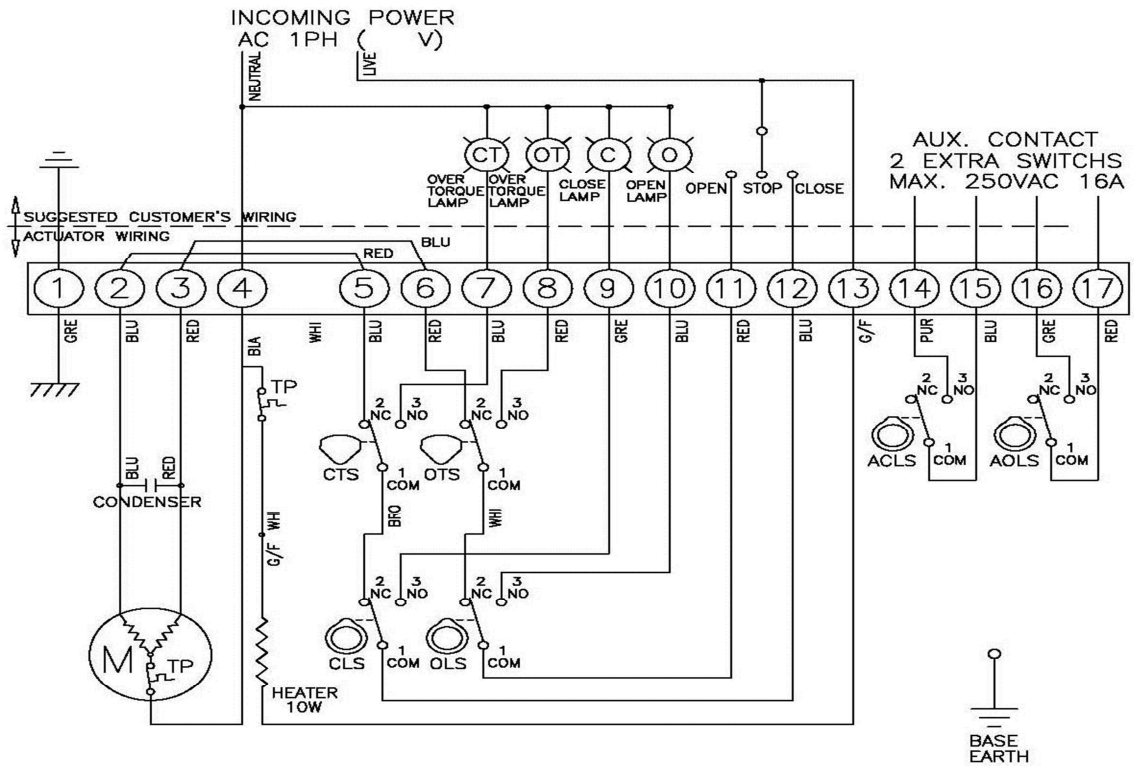

5.2.2. PCU TYPE
(HL 5KN,7KN)

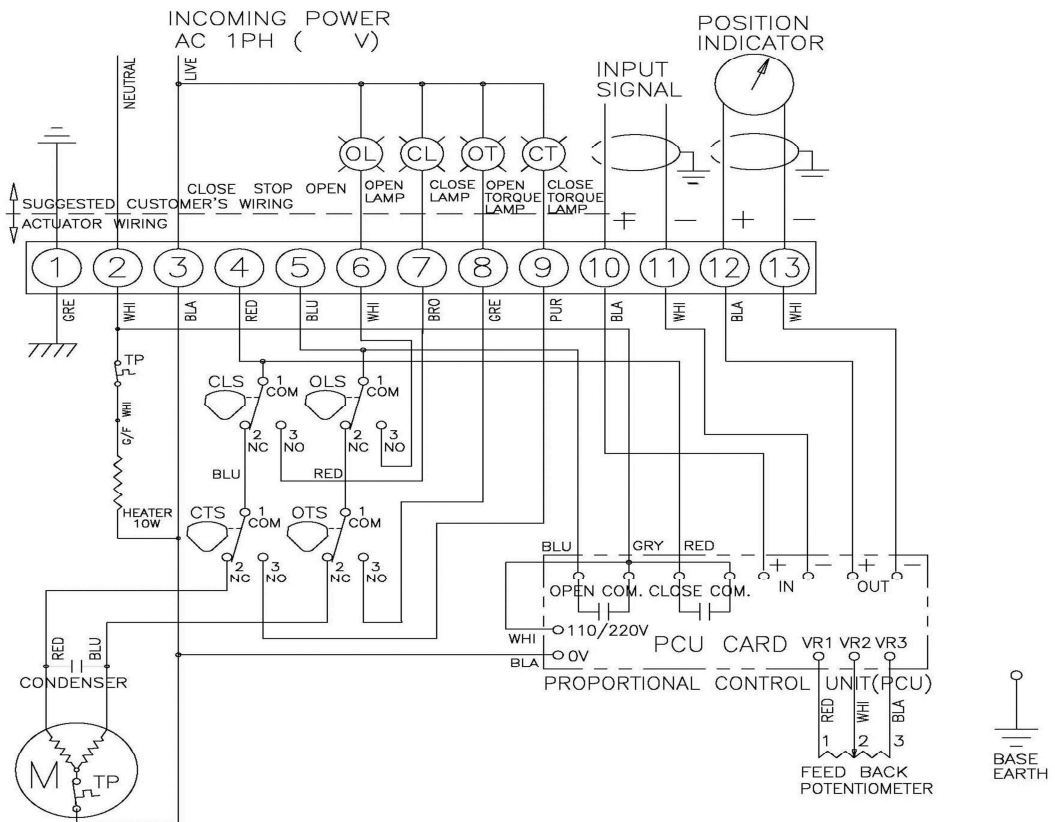

5.2.3. HL 10KN,12KN,15KN,18KN,20KN,25KN

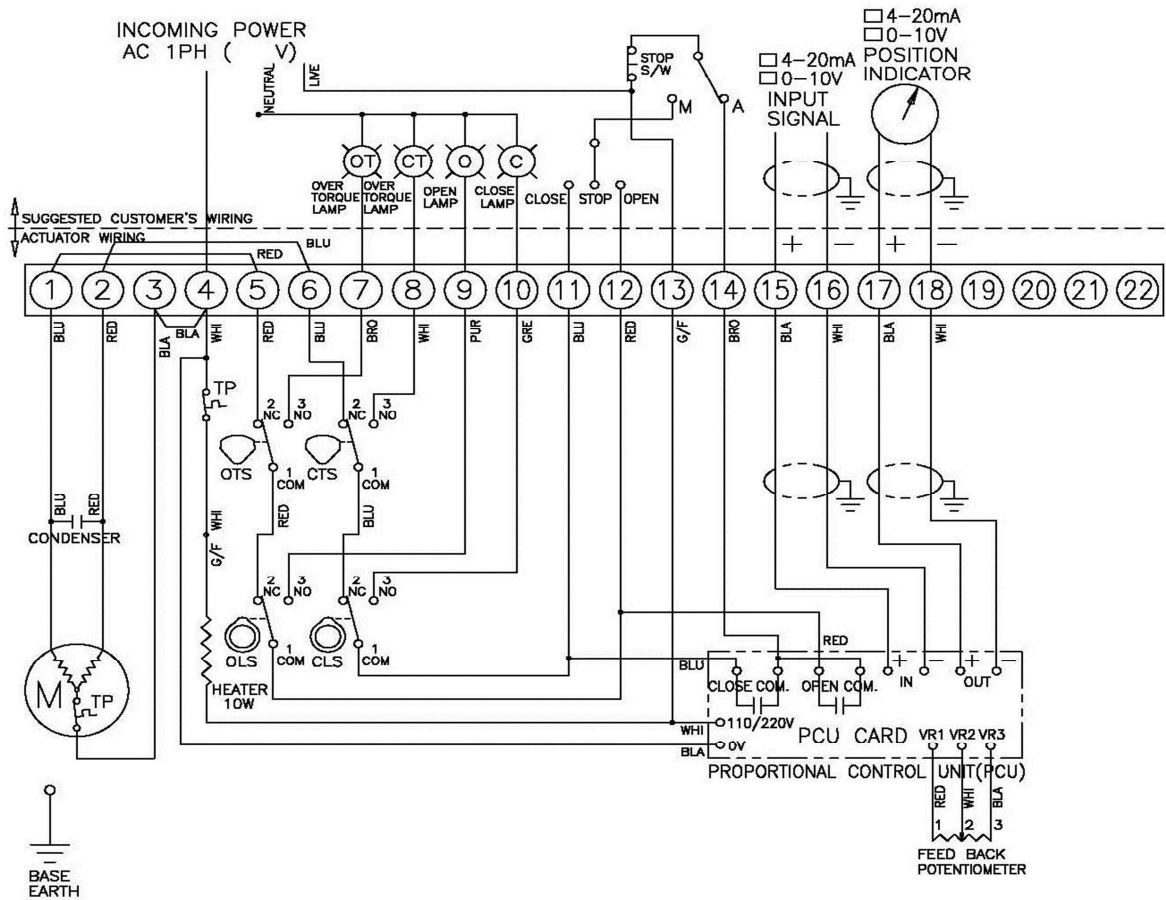

6. Maintenance

6.1. Maintenance



WARNING:

- ✓ Turn off all power before attempting to perform maintenance on the actuator.
- ✓ **POTENTIALLY HIGH PRESSURE VESSEL.** Before removing or disassembling your actuator, ensure that the valve or other actuated device is isolated and not under pressure.

Under the normal conditions, maintenance should be carried out at six month intervals. But when the conditions are more severe, more frequent inspections may be advisable.

- 6.1.1. Ensure that the actuator is properly aligned with the valve or other actuated device
- 6.1.2. Ensure that all wirings are insulated, connected and terminated properly
- 6.1.3. Ensure that all screws are present and tight
- 6.1.4. Ensure cleanness of internal electrical devices
- 6.1.5. Ensure that cable connections are properly installed and are dried
- 6.1.6. Check the internal devices for any condensation
- 6.1.7. Check the power to the internal heater
- 6.1.8. Verify the declutch mechanism
- 6.1.9. Visually inspect the open/close cycle
- 6.1.10. Check whether the o-ring for Ex d enclosure is damaged or not
- 6.1.11. Inspect the identification labels for wear and replace it if necessary

**WARNING:**

- ✓ *Flameproof Enclosure! Before opening, ensure the absence of any gas and voltage*
- ✓ *Treat cover with care. Gap surfaces must not be damaged or dirtied in any way. Do not jam the cover during fitting.*

6.2. Tools

- 6.2.1. Metric Allen Key (Hex Wrench) × 1
- 6.2.2. Screw Driver × 1
- 6.2.3. Metric Spanner × 1
- 6.2.4. Wrench 200mm × 1
- 6.2.5. Wrench 300mm × 1
- 6.2.6. Wire Stripper Long Nose × 1
- 6.2.7. Multi-meter (AC, Dc, Resistance) × 1
- 6.2.8. PCU Board Option: DC Signal Generator (4 - 20mA DC) × 1

7. Trouble Shooting

The following instructions are listed in the order of the most common difficulties encountered during the installation and start-up.

7.1. The actuator does not respond

- 7.1.1. Visually inspect the actuator to check no shipping or handling damage has occurred
- 7.1.2. Verify the line voltage supplied to the actuator; check that the line voltage matches with the rating on the actuator's nameplate
- 7.1.3. Check the internal wiring against the supplied wiring diagram of the actuator
- 7.1.4. Check the limit switch cams

7.2. The actuator is supplied with power but does not operate

- 7.2.1. Verify the line voltage supplied to the actuator; check that the line voltage matches with the rating on the actuator's nameplate.
- 7.2.2. Check that the actuator torque is greater than the valve torque
- 7.2.3. Check the limit switch cams
- 7.2.4. Check that the torque switches have not been tripped
- 7.2.5. Check the mechanical travel stop adjustment
- 7.2.6. Verify that the actuator against the rotation of the valve (standard units are counter-clockwise rotation to open)
- 7.2.7. Check for any corrosion and condensation that any of the electrical or mechanical devices have not been contaminated
- 7.2.8. Verify that coupler/bracket is correctly installed and is not causing any binding

7.3. Actuator runs erratically

- 7.3.1. Check the ambient temperature
- 7.3.2. Verify that the duty cycle has not been exceeded
- 7.3.3. Check the position of manual override lever

7.4. Optional Equipment(s)

- 7.4.1. Potentiometer Current Position Transmitter
 - ① Check the resistance value
 - ② Check potentiometer gear for jamming
 - ③ Check ZERO and SPAN calibration
 - ④ Check the board for any damage
- 7.4.2. Current Position Transmitter
 - ① Verify the input signal
 - ② Check the configuration of the dip switches
 - ③ Check the board for any damage

8. Installation and Maintenance Tips

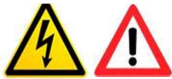

WARNING:

- ✓ *When working in potentially explosive areas, be sure to comply with the standard EN 60079-14 "Electrical Installations in Hazardous Areas".*
- ✓ *Working on the actuator that is in open position and under voltage must only be performed if it is assured that there is no danger of explosion for the duration of the work.*
- ✓ *Flameproof Enclosure! Before opening, ensure the absence of any gas and voltage*
- ✓ *[When operation, maintenance, or installation shall be verified that O-rings are not damaged or pinched between their parts. ---- 15 Rev1]*



CAUTION:

- ✓ *A regular inspection and maintenance should be performed by qualified and trained personnel*
- ✓ *Treat cover with care. Gap surfaces must not be damaged or dirtied in any way. Do not jam the cover during fitting.*
- ✓ *Pay attention to national regulations*

For any installation and maintenance work, the followings should be noted:

- 8.1. Check the quarter turn actuators visually. Ensure that no external damage or changes are visible. The electrical cables must not be damaged and wired correctly.
- 8.2. Cable entries, cable glands, plugs, etc. have to be checked whether they are correctly tightened and sealed.
- 8.3. Check that the Ex-connections are correctly fastened.
- 8.4. Check for the possible discoloration of the terminals and wires as this may indicate an increased temperature.
- 8.5. Check the flame path gaps of the flameproof enclosures for any dirt and corrosion. Since the dimensions of all Ex gaps are strictly defined and inspected, no mechanical work shall be performed on them.
- 8.6. All cables and motor protection elements have to be checked.
- 8.7. During the maintenance if any defects are detected that may affect the safety, repair measures have to be taken immediately.
- 8.8. Any kind of surface coating for the gap surface is not permitted.
- 8.9. When replacing parts, seals, etc., only original spare ones must be used.

9. Dimensions for actuator

9.1. 5KN,7KN, 10KN, 12KN, 15KN, 18KN, 20KN, 25KN (Standard type)

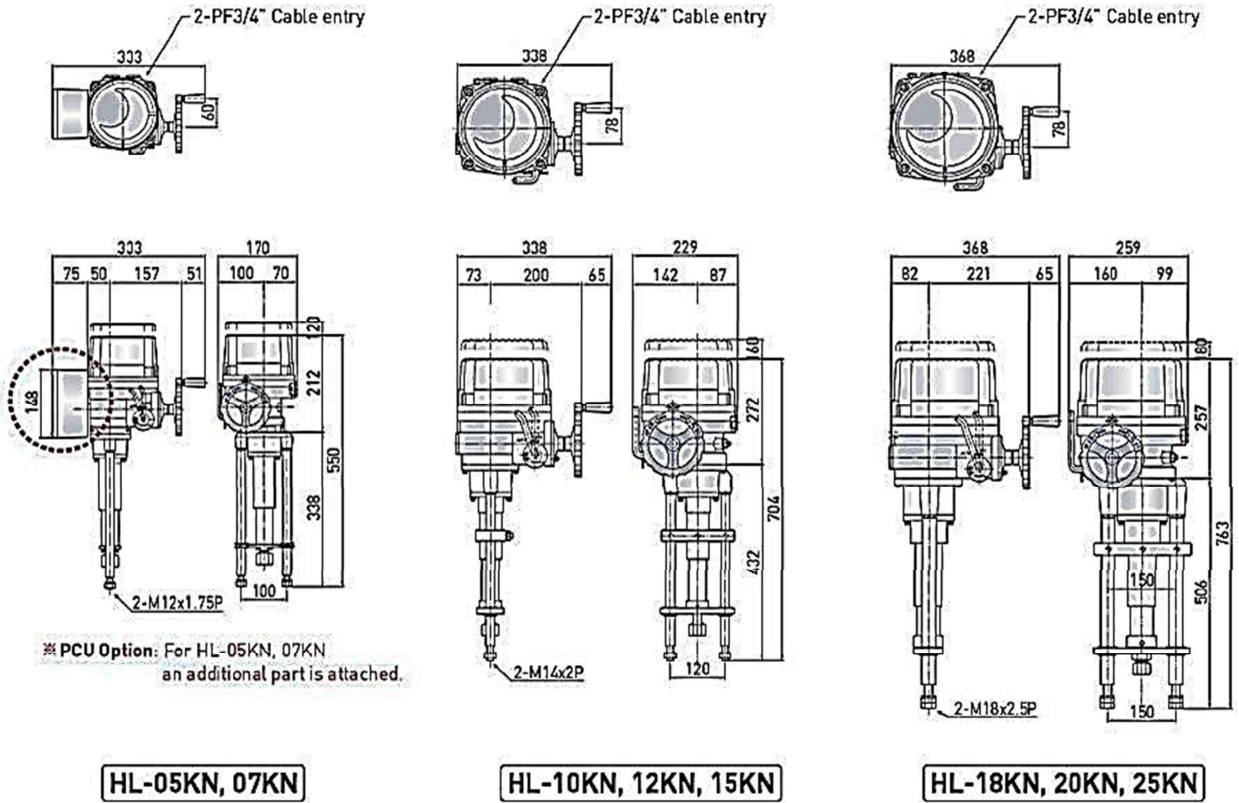

9.2. 5KN,7KN, 10KN, 12KN, 15KN, 18KN, 20KN, 25KN (LCU-B type)

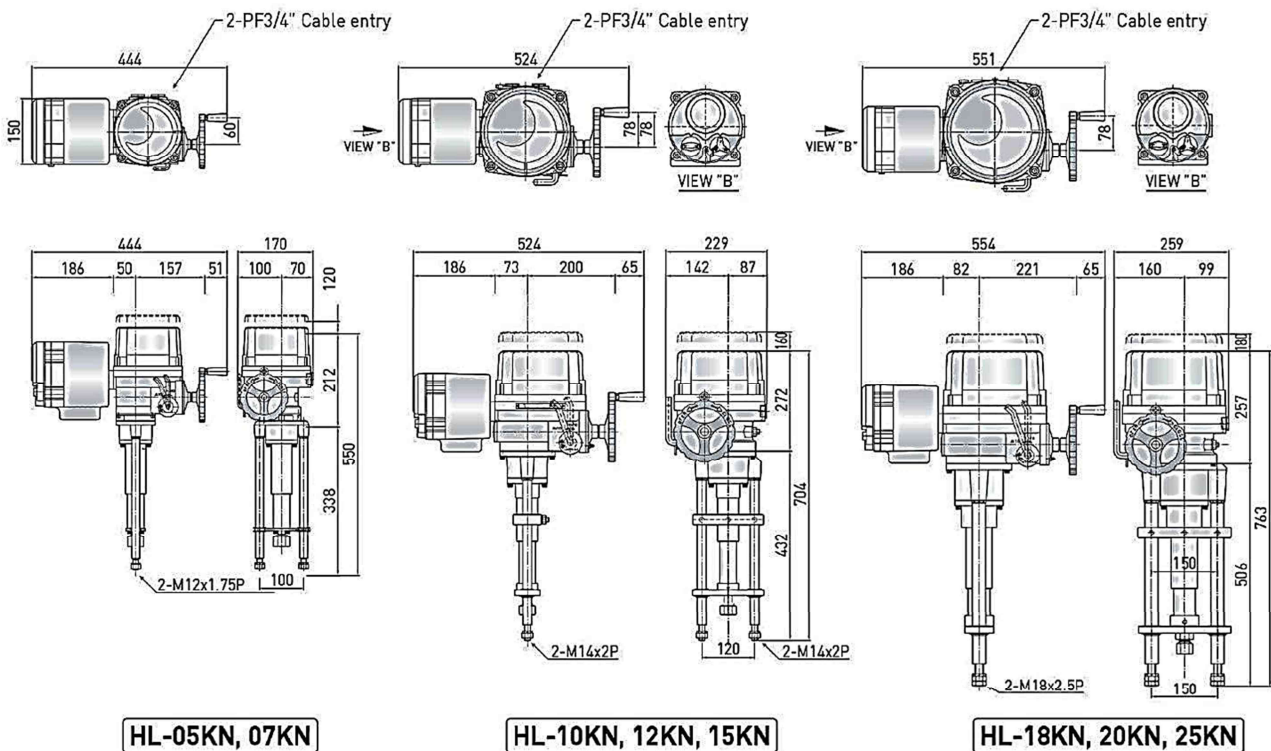

9.3. 5KN,7KN, 10KN, 12KN, 15KN, 18KN, 20KN, 25KN (RBP type)

